

57

# APPLICATION PROPOSAL



## Surge Protection for Petrol Stations

# Surge Protection for Petrol Stations

Due to their size and often exposed location, petrol stations are at special risk of lightning strikes and surges. Electronic devices such as control and display systems are extremely sensitive to lightning currents and surges. Modern petrol stations, however, depend on the safe function of these systems in order to ensure reliable operation, mostly around-the-clock.

In Germany, the necessity of a lightning protection system for petrol stations has to be determined among others on the basis of a risk analysis according to the operational safety regulations (BetrSichV), the technical rules for industrial safety and health (TRBS 2152 Part 3), the applicable standards (VDE) and the fire safety regulations of the regional building regulations (LBO).

The operational safety regulations (BetrSichV) require that any sources of ignition have to be excluded and some regional building regulations read as follows:

*Permanently effective lightning protection systems must be installed on buildings where lightning strikes are likely to occur due to their location design or use or may have severe consequences.*

The risk analysis in Part 2 of the EN/IEC 62305-2 lightning protection standard can be used for a risk assessment. System-specific parameters determine the existing risk of a building or structure. If the determined risks are higher than the acceptable values specified in the standard, measures such as external lightning protection, surge protection and fire protection have to be taken to reduce the existing risks to an acceptable level.

The statement that properties have to be protected from damage caused by surges due to atmospheric interferences or switching operations is already made in subclause 131.6.2 of IEC 60364-1. The surge protective devices suggested here refer to an installation outside of potentially explosive atmospheres (Ex zones 0, 1 and 2). If surge protective devices are installed inside of Ex zones, it has to be ensured by corresponding measures (e.g. cer-

tified enclosures and/or certified surge protective devices) that any ignition is avoided.

Installations outside of the petrol station building such as the petrol price display are endangered by direct lightning strikes and will therefore be protected by lightning current arresters at the building entry. The same applies to the incoming power supply system.

The petrol pumps are located under a metal roof. This is an area which is protected from direct lightning strikes. For this reason and because of the intermeshed earth-termination system surge arresters are installed at the line entrance into the petrol station building and at the line entrance into the petrol pump (**Figure 1**) to protect the conductors leading to the electronics of petrol pumps.

A professionally implemented external lightning protection system according to IEC 62305 in combination with consistent lightning equipotential bonding and supplementary surge protection measures is a basic requirement for an effective protection against direct lightning strikes. The types of surge protective devices suitable for the protection of the individual interfaces and system components are shown in the Table of **Figure 1**.

It is also important that all metal structures such as pipings, petrol pump casings and tanks are interconnected and bonded with the earth-termination system of the petrol station building. According to IEC 62305-3 the earth-termination system should have an earthing resistance  $< 10 \Omega$  (recommendation). Petrol stations with cathodic corrosion protection must only be connected with the earth-termination system via Ex spark gaps.

The bus systems, sensors and IT terminals illustrated in **Figure 1** are exemplarily and shall have no claim to completeness. Exclusively the specifications of the respective detail planning and the indications and instructions of the competent institution are essential for the installation.

# 57 APPLICATION PROPOSAL

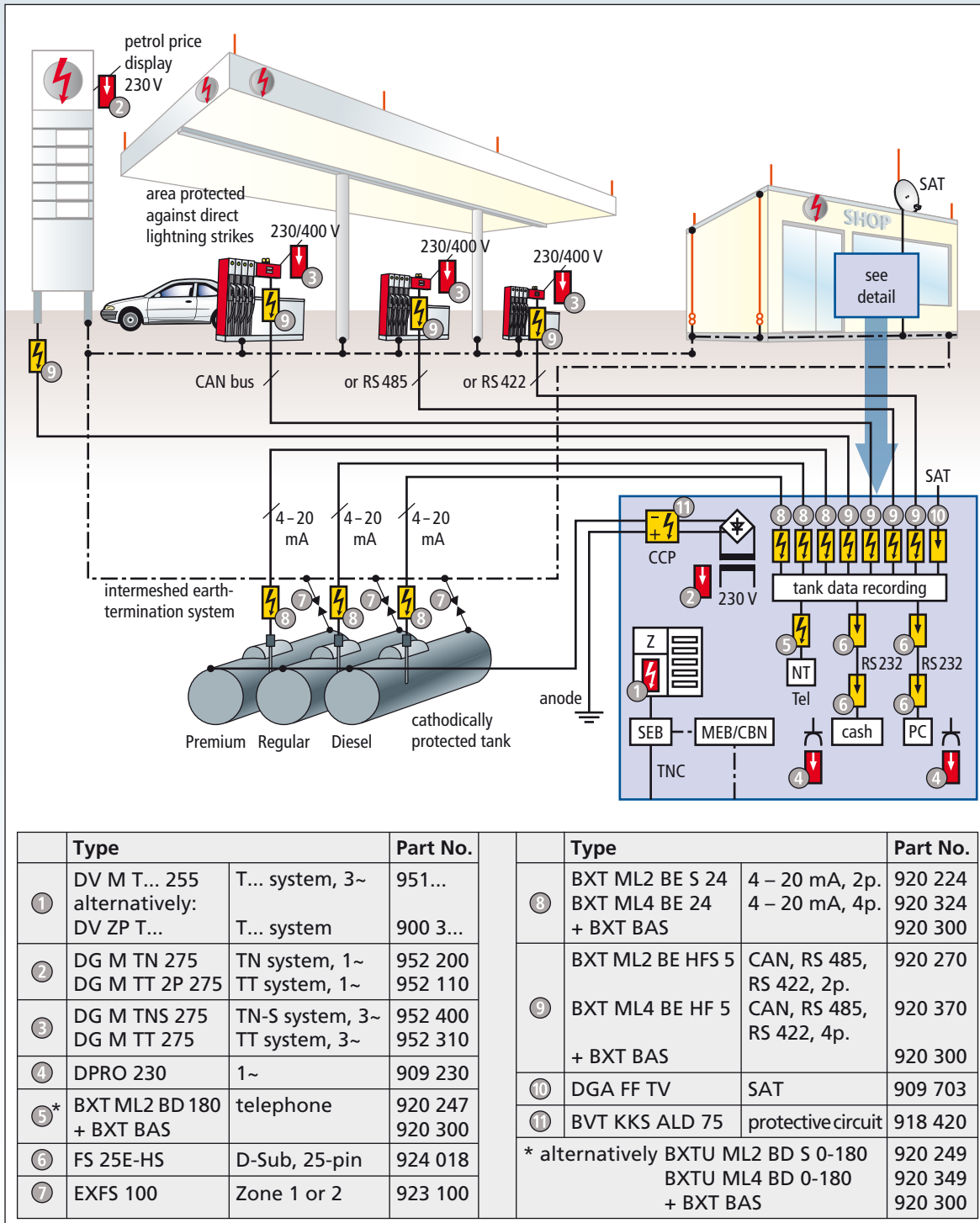

Figure 1 Petrol station with lightning protection system, intermeshed earth-termination system, protective and functional equipotential bonding and surge protective devices



DEHN + SÖHNE  
GmbH + Co.KG.  
Hans-Dehn-Str. 1  
Postfach 1640  
92306 Neumarkt  
Germany

Tel: +49 9181 906-0  
FAX: +49 9181 906-1333  
[www.dehn.de](http://www.dehn.de)  
[info@dehn.de](mailto:info@dehn.de)

Type designations of products mentioned in the application proposal being at the same time registered trademarks are not especially marked. So if there is no marking of <sup>TM</sup> or <sup>®</sup> this does not mean that the type designation is a free trade name. Neither it can be seen whether patents or utility models and other intellectual and industrial property rights are available.

We reserve the right to introduce changes in performance, configuration and technology, dimensions, weights and materials in the course of technical progress. The figures are shown without obligation. Misprints, errors and omissions as well as alterations expected. Reproduction in any form whatsoever is forbidden without our authorisation.